



# 92-518

**02-10 AVALANCHE**  
**05-10 SUBURBAN, YUKON XL**  
**07-10 GM SILVERADO EXT & CREW CAB "Z71"**

(866) 476-6276 / (866)IRONCROSS  
www.ironcrossautomotive.com  
519 W. Dewey  
Sapulpa, OK 74066  
IRON CROSS AUTOMOTIVE INC. 2009

## ENDEAVOUR INSTALLATION SHEET

QTY.	PARTS LIST	QTY.	PARTS LIST
24	5/16" x 1" Hex Bolts	24	5/16" Flange Nuts
24	5/16" Flat Washers	16	8mm Bolts
8	Brackets	12	8mm Flange Nuts
8	Bracket Clamps	8	5/16" Lock Washer
8	Bracket Brace 		
6	8mm Nut Clip/U-Nut (Silverado only)		

### MAINTENANCE AND CARE

Only use mild soap for regular cleaning. For heavy build up, a solution of ammonia and water can be used. Never use an abrasive material, i.e. steel wool, for cleaning purposes. Use terry cloth towels wiping in the direction of the tube at all times.

**STEP 1** Remove contents from box and check for damage parts. Verify all parts are present, making sure to read and understand instructions before beginning.

**STEP 2 Mount brackets to pinch weld and vehicle.**

- 1) There are 6 to 8 tabs in the pinchweld that have holes or factory threaded nuts in them. These holes line up with the factory threaded holes in the sidewall
- 2) Pick 4 holes on each side equally spaced to mount brackets.
- 3) Bolt the bracket brace to the bracket using a 5/16" x1" hex bolt, flat washer and 5/16" flange nut.
- 4) Position the bracket and thread a 8mm hex bolt and 5/16 flat washer up through the bracket brace and pinchweld. Hand tighten with 8mm flange nut.

**(05-07 thread 8mm bolt, lock washer and 5/16 flat washer into factory welded nuts on pinch weld) Fig 1**

- 5) Bolt the top of the brackets on by inserting a 8mm x 1" hex bolt, flatwasher and lock washer through the slot in the bracket and into the factory threaded hole.

**(05-07 use 8mm nut, lock washer and 5/16 flat washer on factory studs for front and rear brackets)**

- 6) **2007-08 Silverado "Z71"** - remove rubber plug and insert 8mm nut clips into 2 rear hole mounting positions and thread a 8mm bolt, flat washer and lock washer into clip. **Fig 2**  
**Z71 Extended cabs** use NUT CLIPS at front, middle and rear bracket mounting positions.

**STEP 3 Mounting board to vehicle.**

- 1) Place clamp brackets on main bracket, turn 90 degrees to the main brackets. Place 5/16" hex bolt through top of bracket clamp in oblong hole to center hole in main bracket, placing 5/16" flange nut on bottom side. Fig 2a
- 2) Place running board on main brackets, making sure that opening and the bottom of the board goes over the clamp brackets.
- 3) Rotate clamp brackets above main brackets, making sure that both edges of the running board are in between the clamp bracket and the main bracket. Install 5/16" hex bolt through center hole of bracket clamp and oblong hole of main bracket placing 5/16" flange nut on bottom side. Fig 2b
- 4) Adjust board to be centered under the cab of the vehicle and tighten the clamp brackets to the main brackets. Make sure all remaining hardware is tightened and test the running boards for attachments.

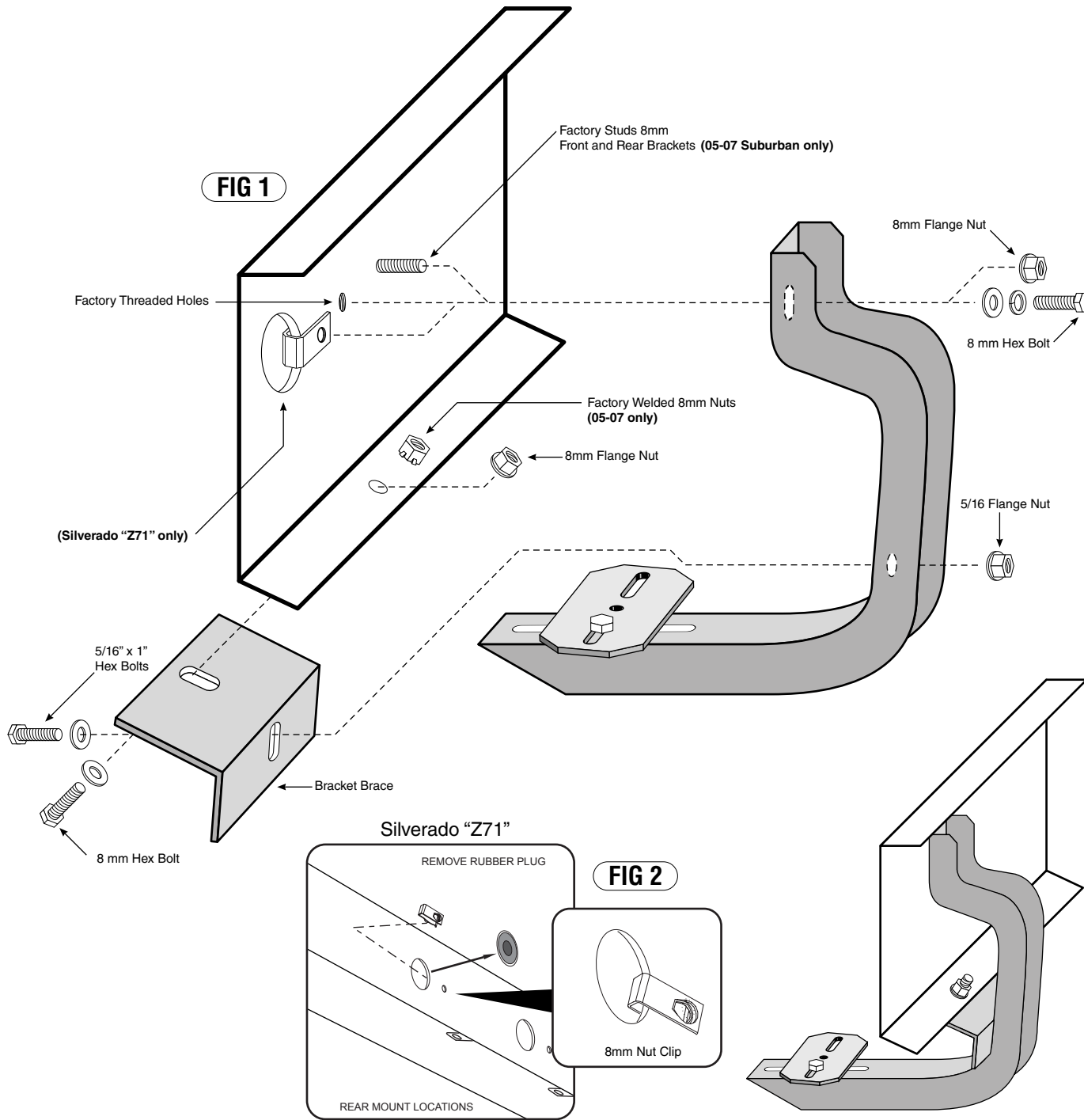

## MOUNTING BOARD TO BRACKET

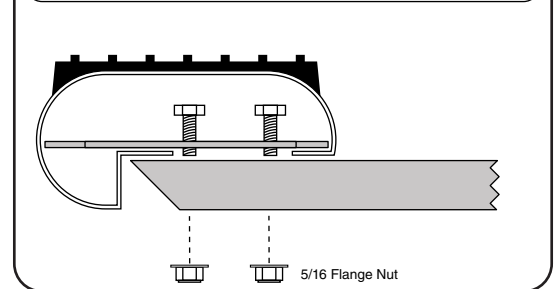
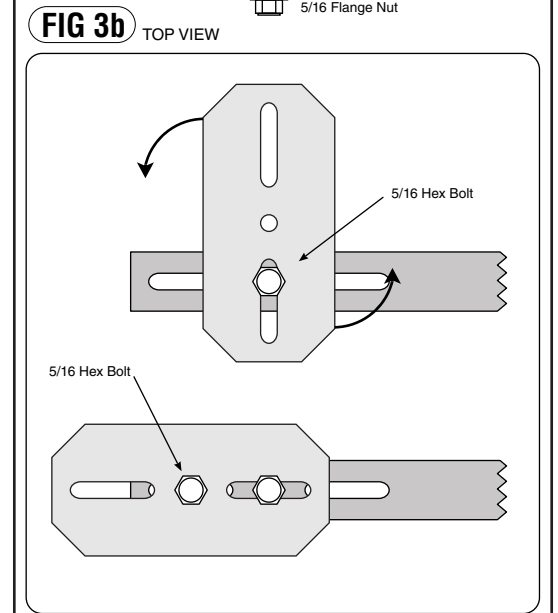
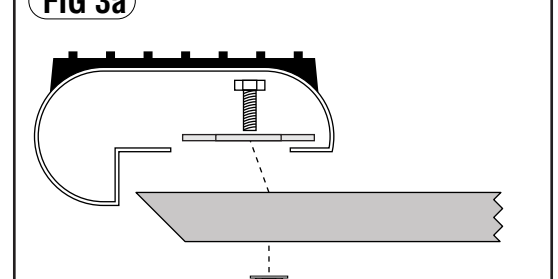
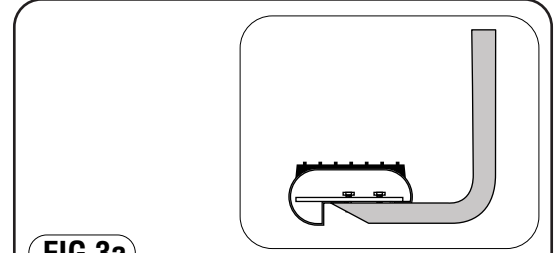

**2002-08 AVALANCHE, 2005-08 SUBURBAN, YUKON XL**