

PARTS LIST

QTY	PARTS	QTY	PARTS	QTY	PARTS
34	5/16" X 1.25" Hex Bolt	16	3/8" Flange Bolt (4 pre installed)	8	Full Bracket
36	5/16" Flat Washer	16	Rail tabs (4 pre installed)	1	D/F Half Bracket
18	5/16" Lock Washer	18	5/16" Nut Clip	1	P/F Half Bracket
16	5/16" Flange Nut				

(866) 476-6276 / (866) IRONCROSS
www.ironcrossautomotive.com
519 W. Dewey
Sapulpa, OK 74066
IRON CROSS AUTOMOTIVE INC. 2008

****Steps are a separate part number and sold separately.**

BRACKET INSTALLATION

- 1) Remove contents from box and check for damaged parts. Verify all parts are present, making sure to read and understand instructions before install.
- 2) Locate factory holes on inside body panel and pinchweld. **Fig 1** Regular Cabs have (3) mount locations, Super Cabs have (4) and Crew Cabs have (5).
- 3) Install nut clip into factory location. **Fig 2** Hole #3 **Fig 2a** ****SEPERATE INSTALLATION PAGE FOR DRIVER AND PASSENGER FRONT HALF BRACKETS****
- 4) Position the bracket to the pinch weld holes. Install 5/6" hex bolt and 5/16" flat washer through pinch weld and holes "B" on bracket. Thread 5/16" flange nut onto hex bolt and tighten. **Fig 3**
- 5) Install 5/16" hex bolt, lock washer, and flat washer through holes "A" on bracket into nut clips and tighten. **Fig 3**
- 6) Repeat install on passenger side.

TUBE AND RAIL INSTALLATION *(Tubes and rails are not driver and passenger side specific. They fit both sides universally)*

- 1) Tube and rail come preassembled in box. Unassemble tube and rail before install. You may loosen hex bolt and slide rail from tube leaving hex bolt and rail tab on the tube brace.
- 2) Insert 3/8" hex bolt into hole "C" of FRONT bracket and loosely thread rail-tab to bolt a few turns. Slide rail onto rail-tabs. *Hand tighten at this time.* **Fig 4**
- 3) Slide middle bracket rail-tabs into rail and then attach rail to REAR bracket with 3/8" hex bolt and rail-tab. **Fig 5**
Hand tighten at this time.
- 4) Hold rail-tabs with fingers to thread 3/8" hex bolt through MIDDLE brackets into tab and tighten. *Hand tighten at this time.*
- 5) With 3/8" hex bolt and rail-tab fixed to TUBE BRACE, side onto bottom side of rail at near the rear bracket. **Fig 5**
- 6) Attach front of tube to rail by sliding rail-tab in to position and threading 3/8" hex bolt through tube brace. *Hand tighten at this time.*
- 7) Push up on rail when making final adjustments. TIGHTEN ALL REMAINING BOLTS TO COMPLETE INSTALL. 40 FT LBS. MAX TORQ

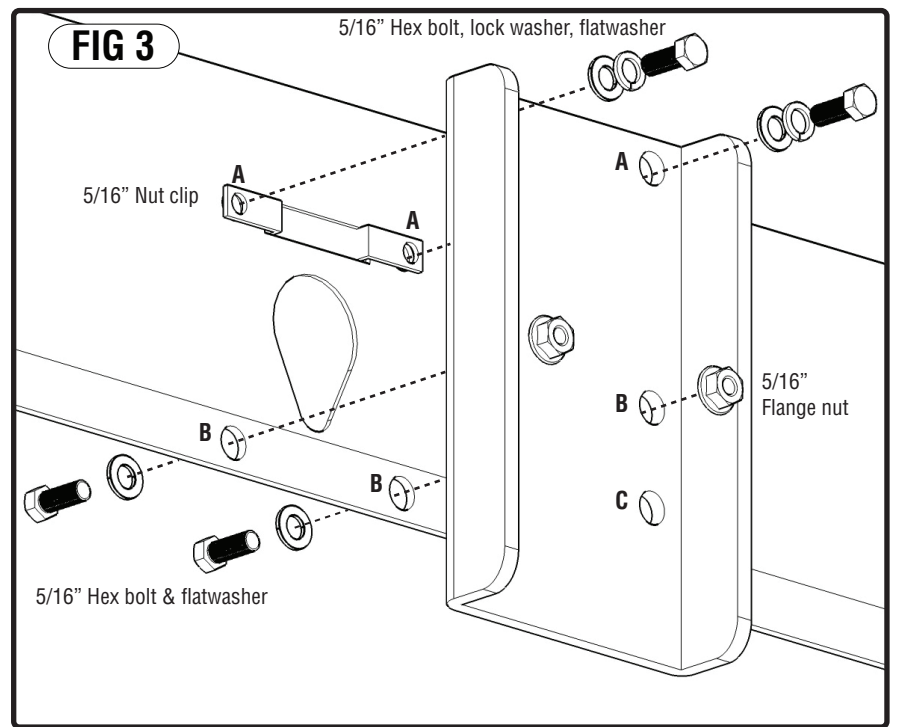
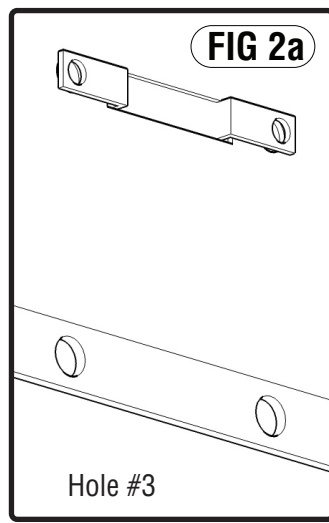
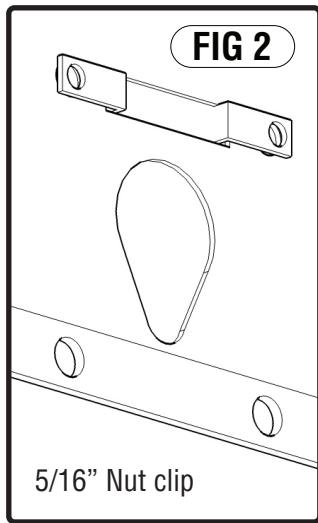
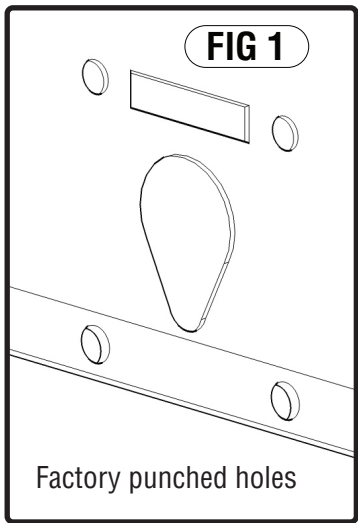

When making final adjustments, we recommend tube to be placed 2-3 inches from the rear of the FRONT wheel well.

Rail should be centered to tube. (1" past inner hole of tube or 5" from tube ends)

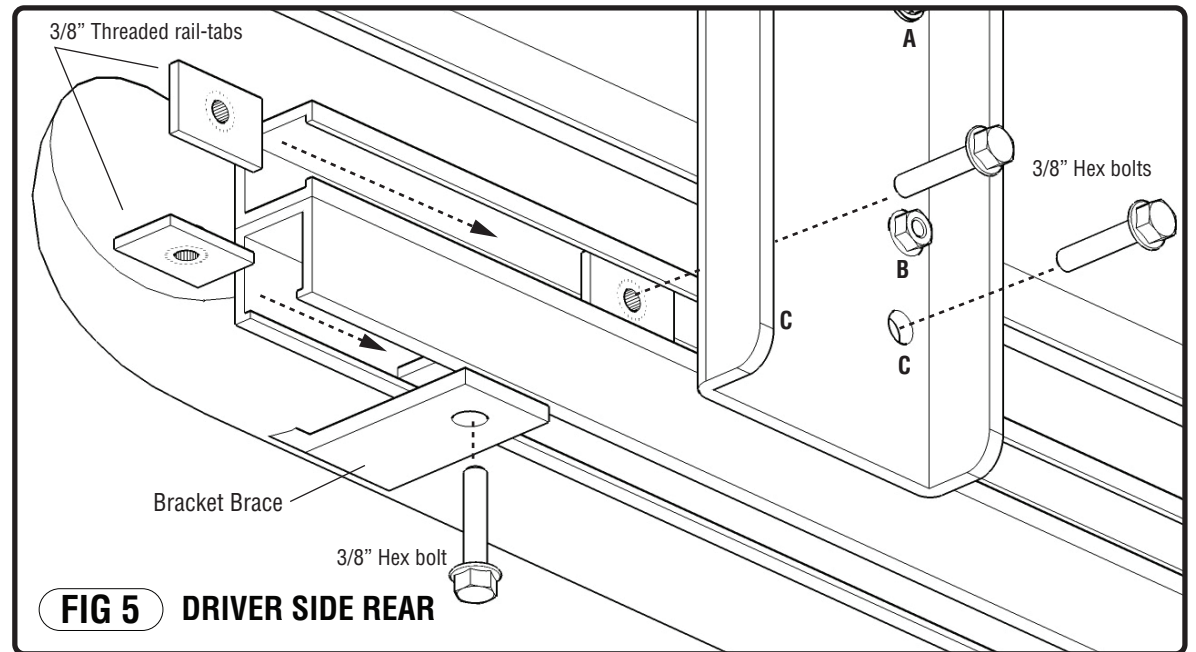
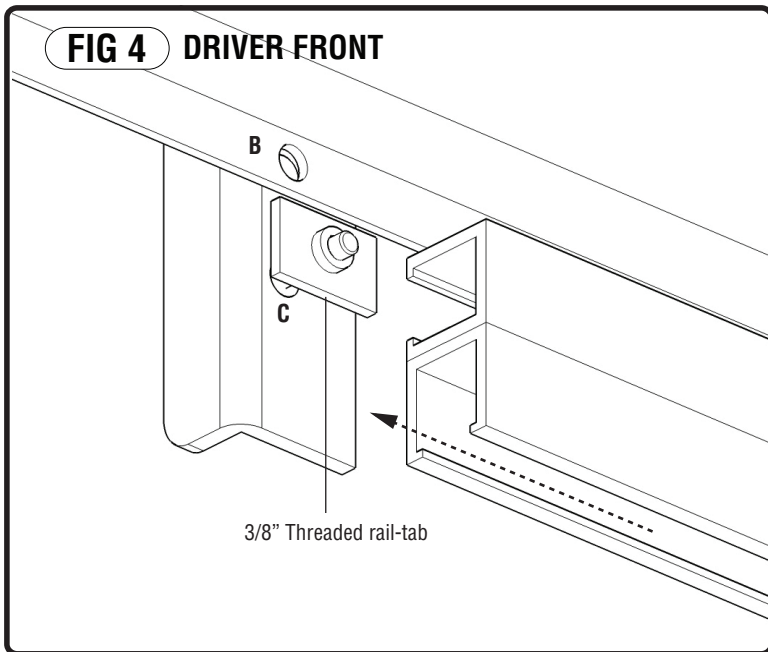
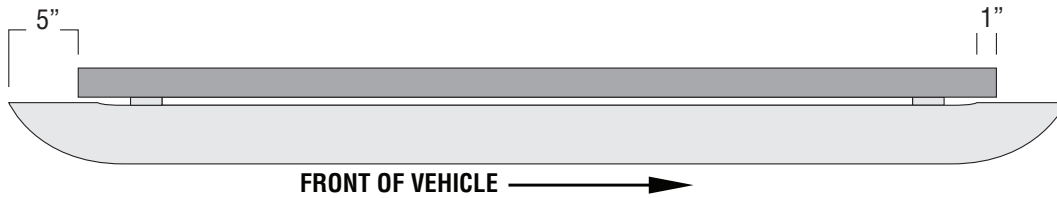

FRONT "HALF" BRACKET INSTALLATION - Driver & Passenger

This mounting location is the first set of holes towards front of body side panel. This location will have a raised bevel on the pinch weld.

