



# 04-06 Toyota Tundra Double Cab

## 51-708

(866) 476-6276 / (866) IRONCROSS  
www.ironcrossautomotive.com  
519 W. Dewey  
Sapulpa, OK 74066  
IRON CROSS AUTOMOTIVE INC. 2007

# TUBE STEP INSTALLATION SHEET

- STEP 1** REMOVE ALL CONTENTS FROM THE BRACKET BOX AND CHECK FOR CORRECT QUANTITY AND ANY DAMAGED PARTS
- STEP 2** INSTALL FRAME LOCKING BOLTS INTO THE OBLONG HOLES IN THE FRONT FRAME HOLES. **(FIG 1 & 2)**
- STEP 3** INSTALL FRONT BRACKETS USING THE FRAME LOCKING BOLTS, PLASTIC WASHER, 7/16" FLAT WASHERS , 7/16" LOCK WASHERS AND 7/16" HEX NUTS. **(FIG 3)** HAND TIGHTEN ALLOWING FOR FINAL ADJUSTMENTS.
- INSTALL REAR BRACKETS USING THE 1/2" X 1-3/4" HEX BOLTS, 1/2" FLAT WASHERS AND 1/2" LOCK WASHERS. **(FIG 4)** HAND TIGHTEN ALLOWING FOR FINAL ADJUSTMENT.
- STEP 4** THE TUBES ARE UNIVERSAL FROM PASSENGER TO DRIVER SIDE. BOLT THE TUBE TO THE BRACKETS USING THE 1/2" X 1-3/4" HEX BOLTS, 1/2" FLAT WASHERS AND 1/2" LOCK WASHERS. HAND TIGHTEN THE BOLTS. NEXT, ALIGN THE TUBE WITH THE TRUCK AND TIGHTEN THE TUBE STEP BOLTS TO 65 FT/LBS. FINALLY, TIGHTEN THE BRACKET BOLTS TO 35 FT./LBS. **(FIG 5)**
- STEP 5** REPEAT STEPS 2 THROUGH 4 FOR INSTALLATION OF PASSENGER SIDE

QTY.	PARTS LIST	QTY.	PARTS LIST
2	1708 FRONT BRACKETS	6	1/2" FLAT WASHERS
2	1708 REAR BRACKETS	6	1/2" LOCK WASHERS
6	1/2" x 1-3/4" HEX BOLTS	2	TUBE STEPS
2	FRAME LOCKING BOLTS	2	1/2" HEX NUTS
2	7/16" FLAT WASHERS	2	7/16" HEX NUTS
2	7/16" LOCK WASHERS		

### MAINTENANCE AND CARE

Only use mild soap for regular cleaning. For heavy build up, a solution of ammonia and water can be used. Never use an abrasive material, i.e. steel wool, for cleaning purposes. Use terry cloth towels wiping in the direction of the tube at all times.

## REAR BRACKETS PASSENGER



FIG 4

## FRONT BRACKETS PASSENGER

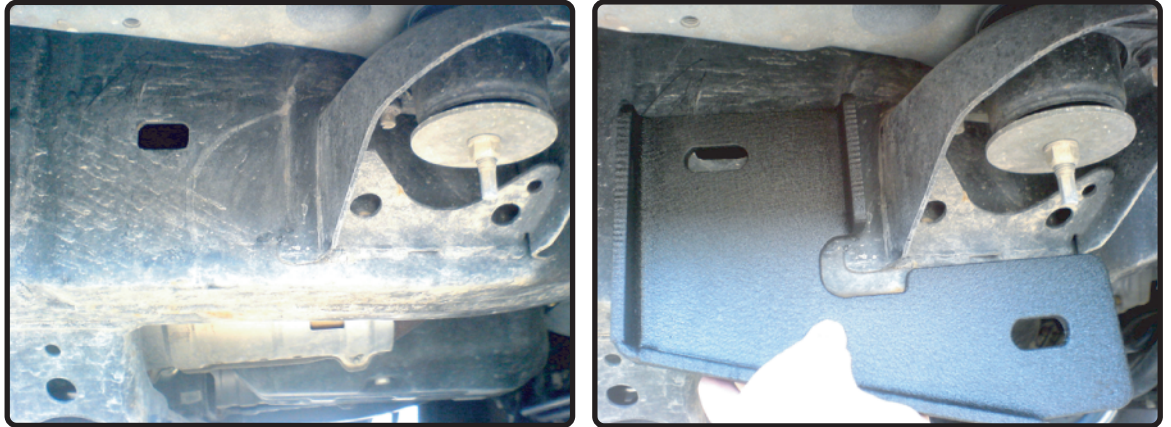

FIG 3

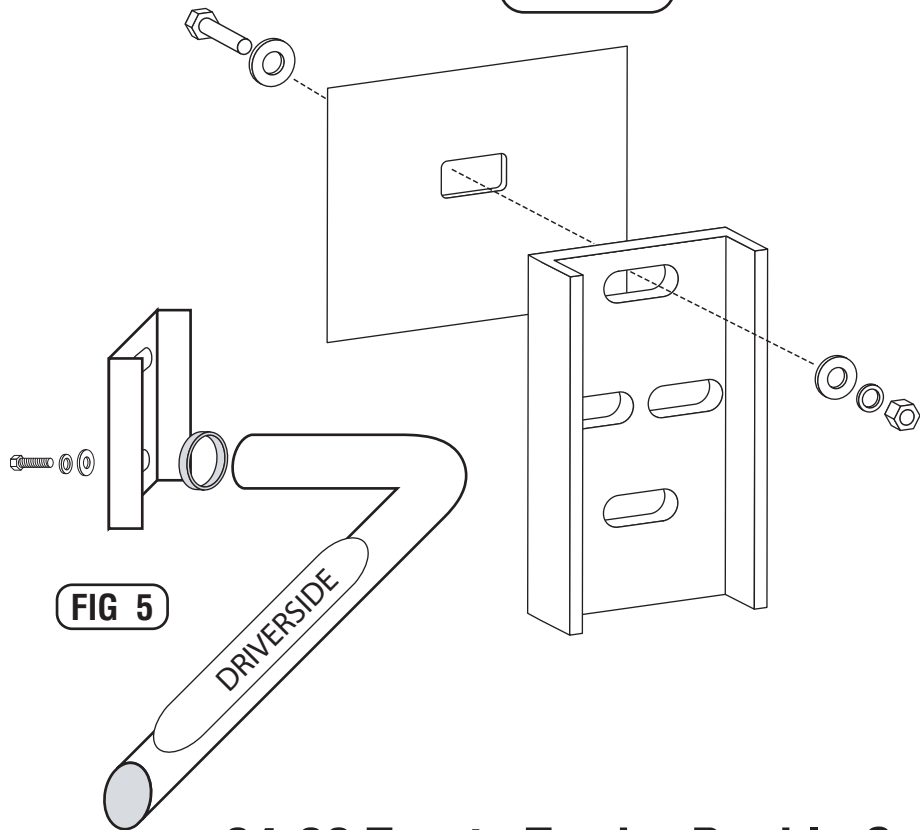
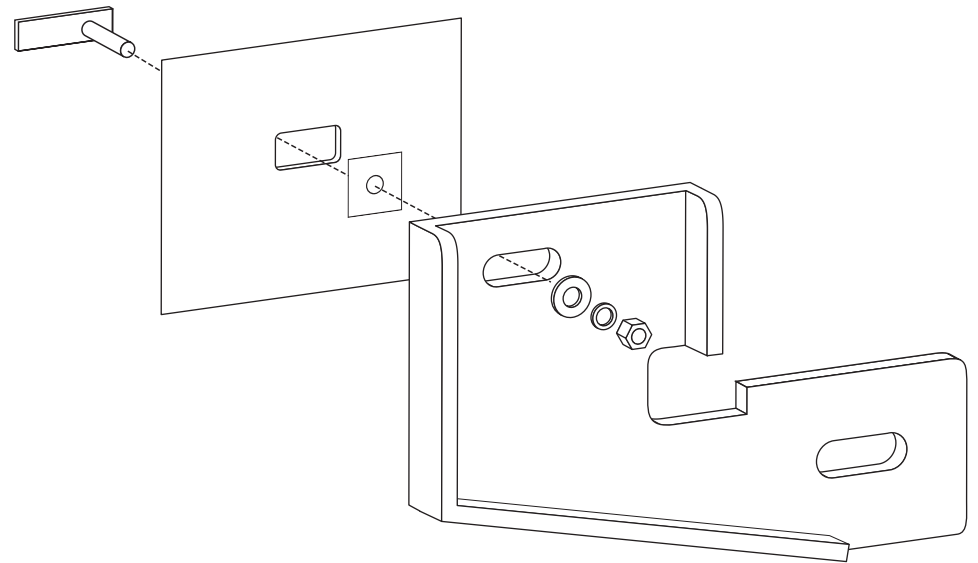

FIG 5



## 04-06 Toyota Tundra Double Cab

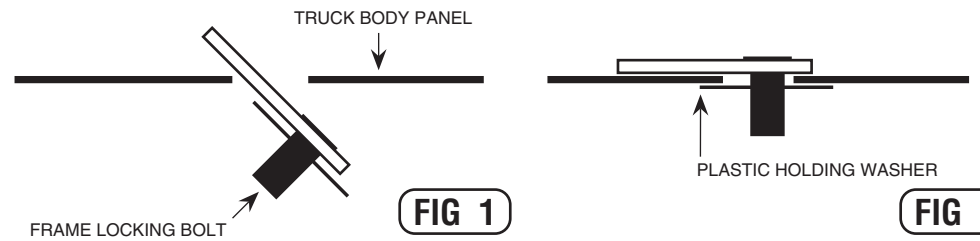

FIG 1

FIG 2