



**99-03 Toyota Tundra Access Cab
01-04 Toyota Tacoma Access Cab
04-06 Toyota Tundra Double Cab
01-04 Toyota Tacoma Double Cab**

51-700/702,704,710

(866) 476-6276 / (866) IRONCROSS
www.ironcrossautomotive.com
519 W. Dewey

TUBE STEP INSTALLATION SHEET

STEP 1 REMOVE ALL CONTENTS FROM THE BRACKET BOX AND CHECK FOR CORRECT QUANTITY AND ANY DAMAGED PARTS

STEP 2 INSTALL FRAME LOCKING BOLTS INTO THE SQUARE HOLES IN THE FRAME, AS SHOWN IN FIG. 1 & 2.

TACOMA TRUCKS USE THE LOWER MOUNTING HOLES IN THE BRACKET

STEP 3

TUNDRA TRUCKS USE THE UPPER MOUNTING HOLES IN THE BRACKET

STEP 4 INSTALL FRONT AND REAR BRACKETS USING HARDWARE DESCRIBED. HAND TIGHTEN ALLOWING FOR FINAL ADJUSTMENTS. THE FRONT MOUNTING BRACKET SHOULD SIT FLUSH WITH THE BODY SUPPORT MOUNT.

STEP 5 THE TUBES ARE UNIVERSAL FROM SIDE TO SIDE. BOLT THE TUBE TO THE BRACKETS USING HARDWARE DESCRIBED. HAND TIGHTEN THE BOLTS. ALIGN THE TUBE WITH THE TRUCK AND TIGHTEN THE TUBE STEP BOLTS FIRST TO 65 FT./LBS. THEN TIGHTEN THE BRACKET BOLTS TO 35 FT./LBS.

STEP 6 REPEAT STEPS 2 THROUGH 6 FOR INSTALLATION OF PASSENGER.

QTY.	PARTS LIST	QTY.	PARTS LIST
2	1700 FRONT BRACKETS	8	½" FLAT WASHERS
2	1700 REAR BRACKETS	8	½" LOCK WASHERS
8	½" X 1 -3/4" HEX BOLTS	2	TUBE STEPS
4	FRAME LOCKING BOLTS		

MAINTENANCE AND CARE

Only use mild soap for regular cleaning. For heavy build up, a solution of ammonia and water can be used. Never use an abrasive material, i.e. steel wool, for cleaning purposes. Use terry cloth towels wiping in the direction of the tube at all times.

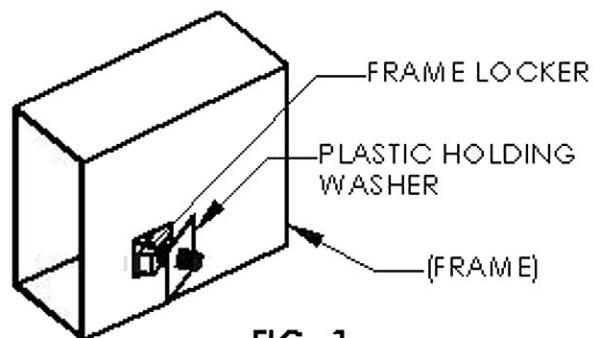

FIG. 1

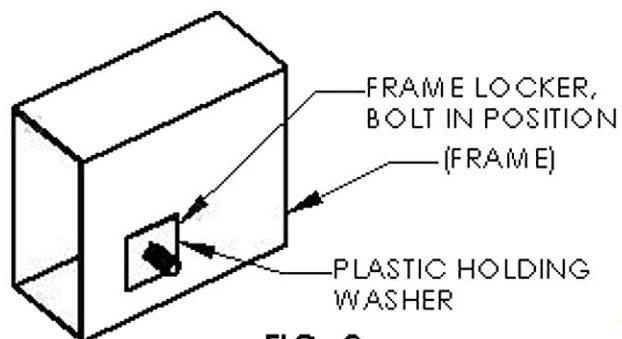

FIG. 2

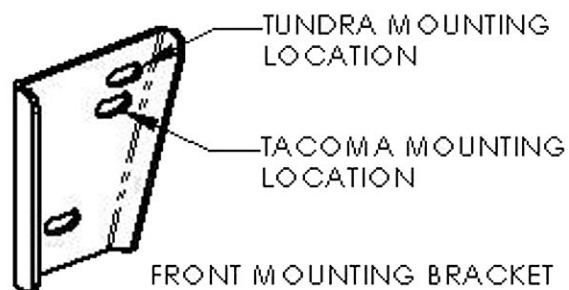

FIG. 3

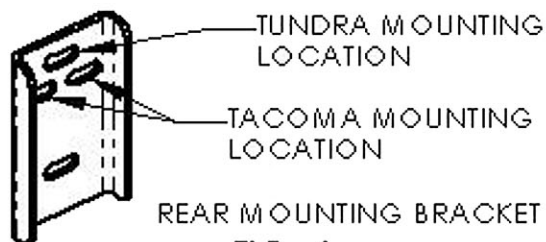
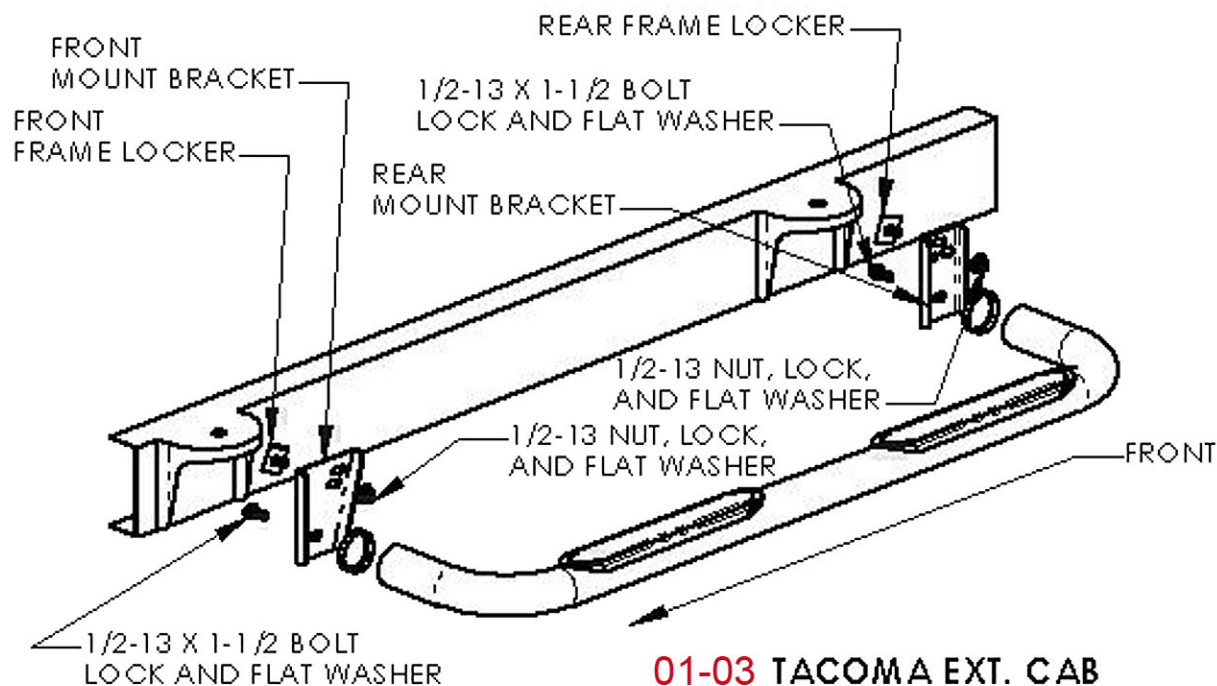
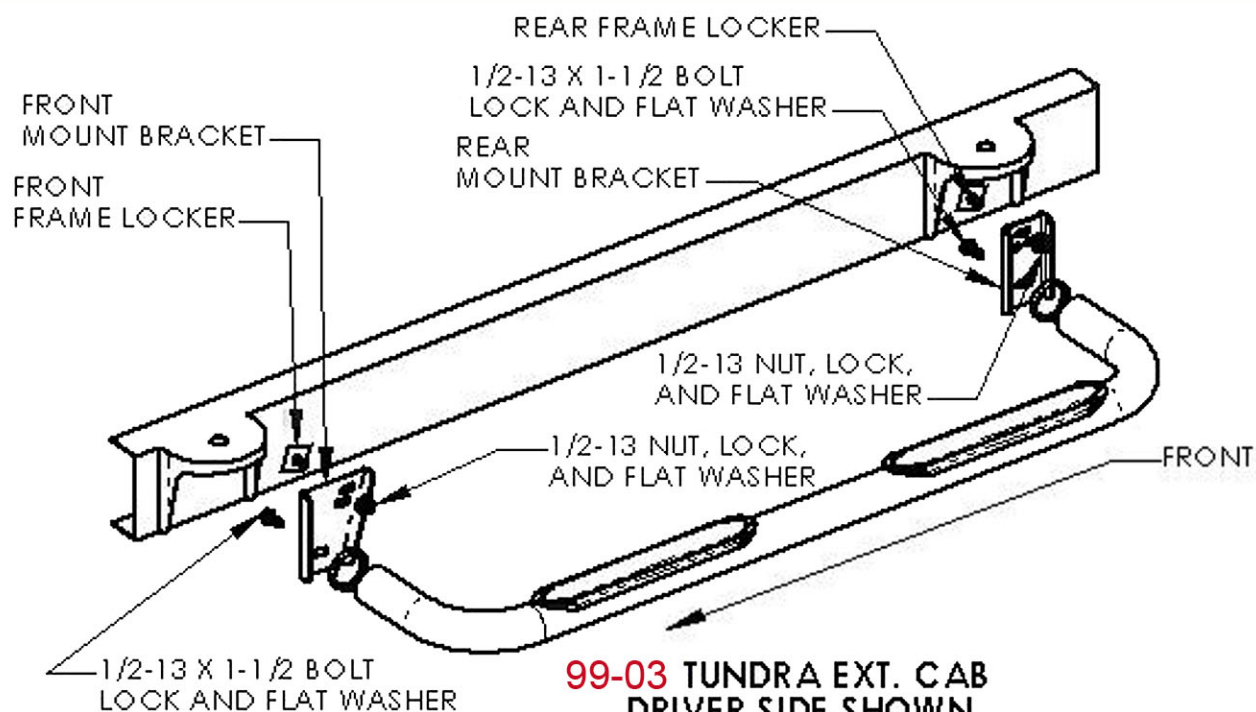

FIG. 4



01-03 TACOMA EXT. CAB DRIVER SIDE SHOWN



99-03 TUNDRA EXT. CAB DRIVER SIDE SHOWN