



## 09-10 FORD F-150 Regular Cab

**51-464**

(866) 476-6276 / (866) IRONCROSS

www.ironcrossautomotive.com

519 W. Dewey

Sapulpa, OK 74066

IRON CROSS AUTOMOTIVE INC. 2008

# TUBE STEP INSTALLATION SHEET

- STEP 1** REMOVE ALL PARTS FROM THE BRACKET BOX AND CHECK FOR CORRECT QUANTITY AND ANY DAMAGED PARTS.
- STEP 2** INSTALL THE FRONT BRACKET BY REMOVING TAPE AND INSERTING NUT CLIPS INTO THE BODY PANEL. REMOVE THE TAPE OVER THE LARGER HOLE AS IN ILLUSTRATION AND INSERT THE FRAME LOCKER. BOLT UP THE BRACKET USING THE HARDWARE DESCRIBED IN THE ILLUSTRATION. HAND TIGHTEN AT THIS TIME ALLOWING FOR FINAL ADJUSTMENTS.
- STEP 3** INSTALL THE REAR BRACKET BY REMOVING THE TAPE AND INSERTING NUT CLIPS INTO THE BODY PANEL. REMOVE THE TAPE OVER THE LARGER HOLE AS SHOWN IN ILLUSTRATION AND INSERT THE FRAME LOCKER. BOLT UP THE BRACKET USING THE HARDWARE DESCRIBED IN ILLUSTRATION. HAND TIGHTEN AT THIS TIME TO ALLOW FOR FINAL ADJUSTMENT.
- STEP 4** BOLT THE TUBE STEP TO THE BRACKETS AS SHOWN USING THE DESCRIBED HARDWARE. BOLT THE TUBE TO THE FRONT BRACKET FIRST.
- STEP 5** INSURE ALL PARTS ARE PROPERLY ALIGNED AND TIGHTEN ALL BOLTS. TIGHTEN THE TUBE STEP BOLTS FIRST TO 65 FT./LBS. TIGHTEN THE BRACKET BOLTS NEXT TO 35 FT./LBS.
- STEP 6** REPEAT STEPS 2 THROUGH 5 FOR INSTALLATION OF PASSENGER SIDE.

QTY	PARTS LIST	QTY	PARTS LIST
4	1/2" BOLTS	8	5/16" SERRATED FLANGE BOLTS
6	1/2" FLAT WASHERS	8	5/16" SERRATED FLANGE NUTS
6	1/2" LOCK WASHERS	8	5/16"x1" HEX BOLTS
2	1/2" NUTS	8	5/16" FLAT WASHERS
8	5/16" NUT CLIPS	2	1/2" FRAME LOCK BOLTS
		2	3/8" FRAME LOCK BOLTS

### MAINTENANCE AND CARE

Only use mild soap for regular cleaning. For heavy build up, a solution of ammonia and water can be used. Never use an abrasive material, i.e. steel wool, for cleaning purposes. Use terry cloth towels wiping in the direction of the tube at all times.

RV2.15.10

VIEW OF DRIVER SIDE REAR BRACKET

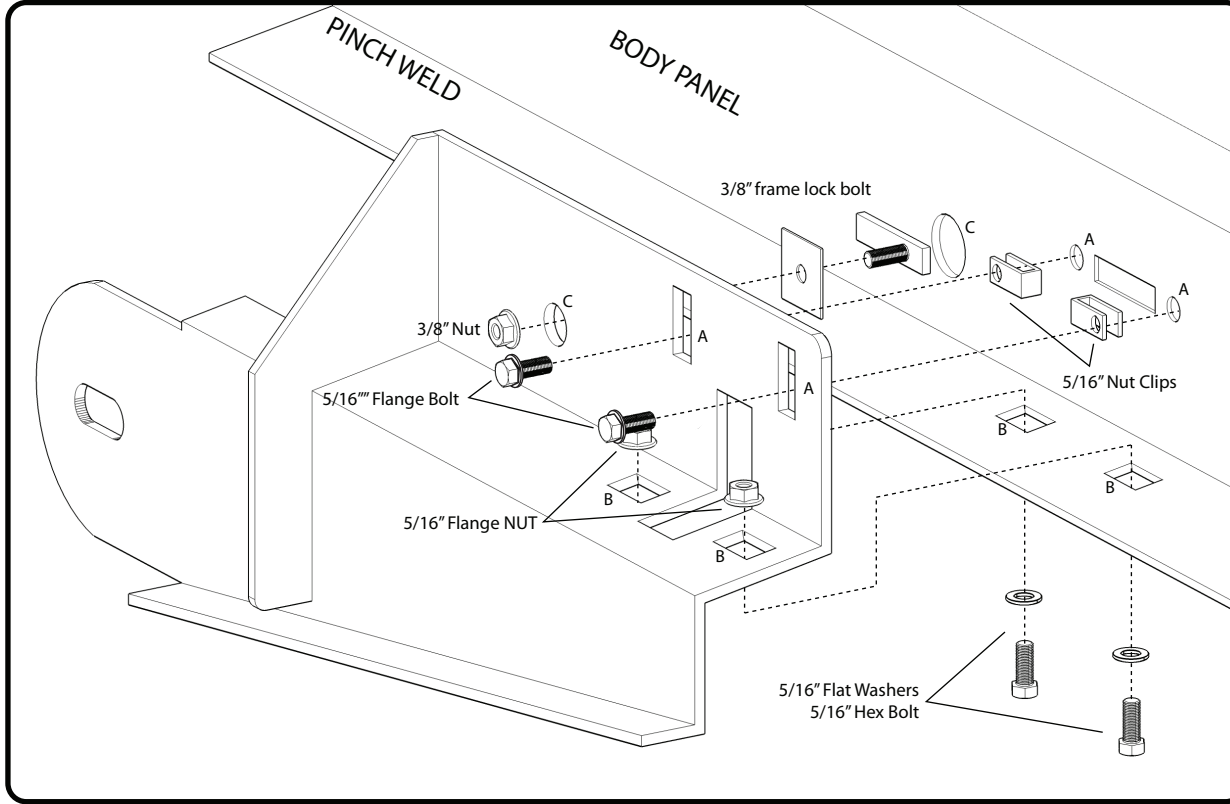

FRAME LOCK BOLT INSTALL

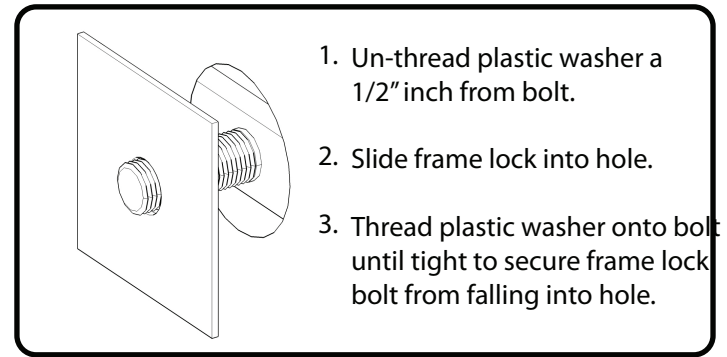

NUT CLIP INSTALL

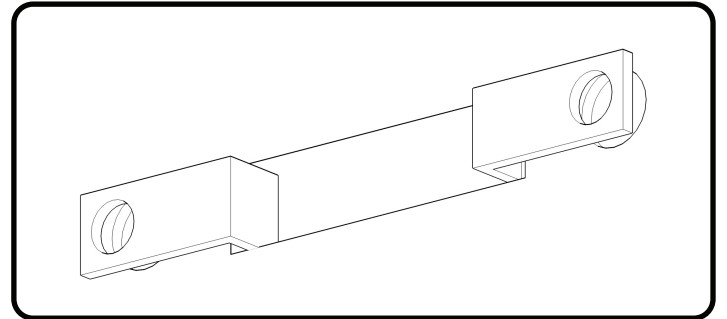

VIEW OF DRIVER FRONT BRACKET

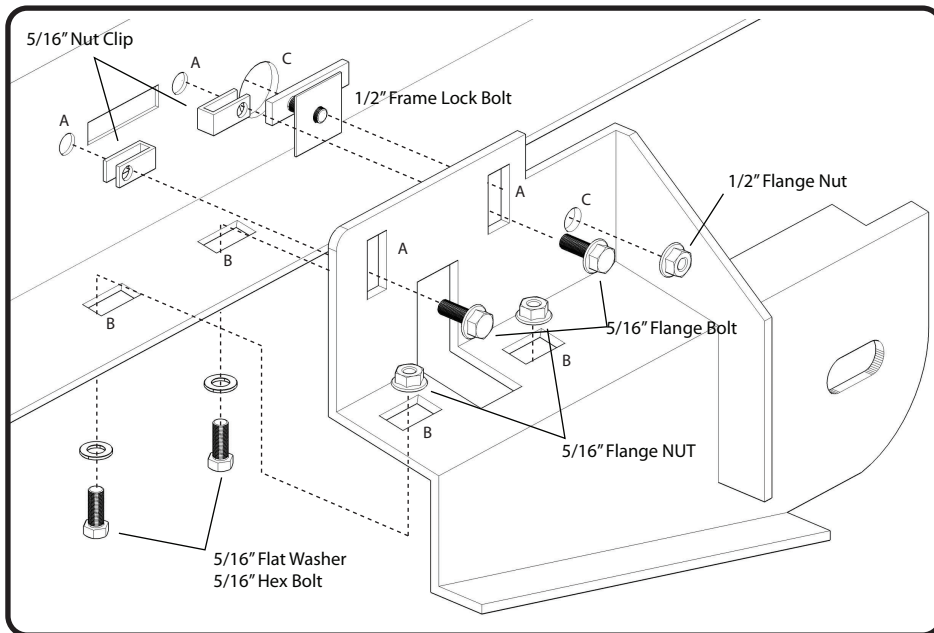

TUBE TO BRACKET INSTALL

