



04-08 F-150 Super Cab and Super Crew

51-422,424

(866) 476-6276 / (866) IRONCROSS

www.ironcrossautomotive.com

519 W. Dewey

Sapulpa, OK 74066

IRON CROSS AUTOMOTIVE INC. 2008

TUBE STEP INSTALLATION SHEET

- STEP 1** REMOVE ALL PARTS FROM THE BRACKET BOX AND CHECK FOR CORRECT QUANTITY AND ANY DAMAGED PARTS.
- STEP 2** REMOVE ALL THE RUBBER PLUGS OVER MOUNTING HOLES LOCATED ON THE INSIDE OF THE VEHICLE ROCKER PANEL. INSTALL FRAME LOCKER BOLTS AND 5/16 "U" NUTS INTO MOUNTING HOLES AS SHOWN.
- STEP 3** ATTACH FRONT AND REAR MOUNT BRACKET BY PLACING BOLTS THROUGH HOLES AS SHOWN.
- STEP 4** FASTEN STEP BARS TO FRONT BRACKET AND REAR BRACKET USING 1/2" BOLTS AND WASHERS SHOWN.
- STEP 5** REPEAT INSTALLATION ON OPPOSITE SIDE OF TRUCK.

QTY	PARTS	QTY	PARTS
2	422 F Bracket	8	5/16" Nut Clip
2	422 R Bracket	8	5/16" Lock Washer
4	1/2" Hex Bolt	20	5/16" Flat Washer
4	1/2" Flat Wash	8	5/16" x 1 1/4" Hex Bolt
4	1/2" Lock Washer	8	3/8" x 1" Hex Bolt
4	3/8" Single Frame Lock Bolt		
12	3/8" Serrated Flange Nut		

MAINTENANCE AND CARE

Only use mild soap for regular cleaning. For heavy build up, a solution of ammonia and water can be used. Never use an abrasive material, i.e. steel wool, for cleaning purposes. Use terry cloth towels wiping in the direction of the tube at all times.

04-08 FORD F-150

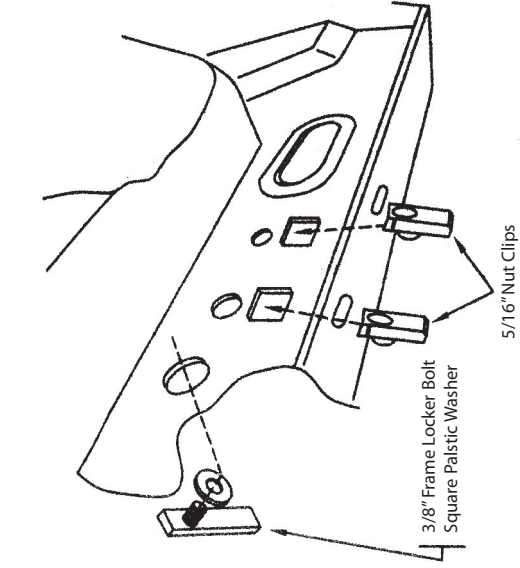

3/8" Frame Locker Bolt
Square Palstic Washer

5/16" Nut Clips

DRIVER SIDE, REAR

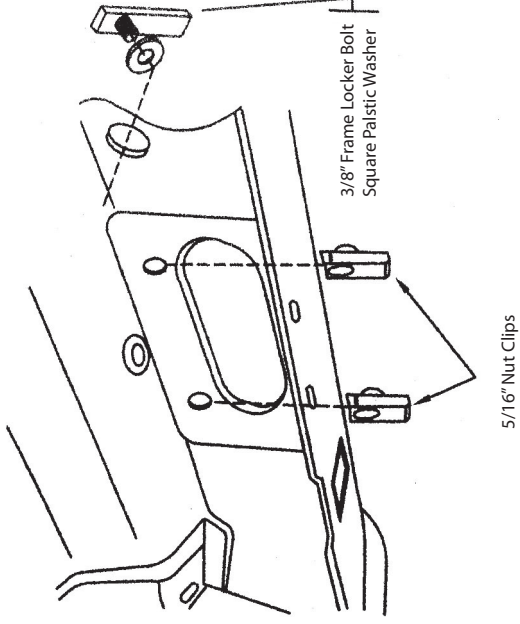

3/8" Frame Locker Bolt
Square Palstic Washer

5/16" Nut Clips

DRIVER SIDE, FRONT

INSTALLATION VIEW OF DRIVER SIDE SHOWN, PASSENGER SIDE OPPOSITE

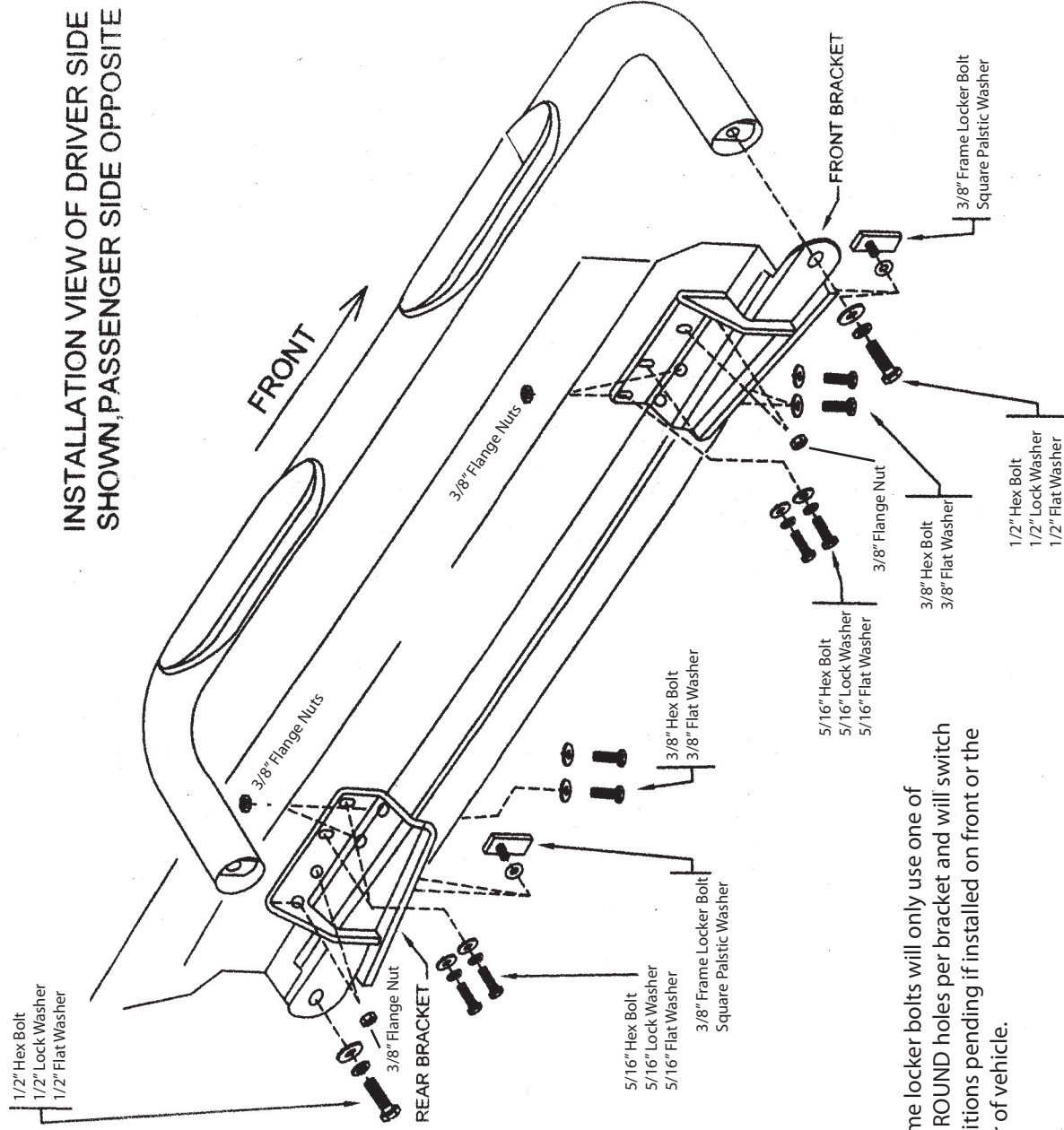

Frame locker bolts will only use one of the ROUND holes per bracket and will switch positions pending if installed on front or the rear of vehicle.