



**99-08 Ford Super Duty 250/350/450/550  
Regular Cab, Super Cab, Crew Cab**

**51-410,412,414**  
 (866) 476-6276 / (866) IRONCROSS  
 www.ironcrossautomotive.com  
 519 W. Dewey  
 Sapulpa, OK 74066  
 IRON CROSS AUTOMOTIVE INC. 2008

# TUBE STEP INSTALLATION SHEET

- STEP 1** REMOVE ALL PARTS FROM THE BRACKET BOX AND CHECK FOR CORRECT QUANTITY AND ANY DAMAGED PARTS.
- STEP 2** INSTALL NUT CLIPS AS SHOWN ONTO BODY PANEL. MAKE SURE THE NUT SIDE OF THE CLIP IS TOWARDS THE INSIDE OF THE PANEL.
- STEP 3** INSTALL FRONT AND REAR BRACKETS AS SHOWN, USING DESCRIBED HARDWARE, DO NOT TIGHTEN AT THIS TIME, TO ALLOW FOR FINAL ADJUSTMENTS.
- STEP 4** BOLT THE TUBE STEP TO THE BRACKET AS SHOWN USING THE DESCRIBED HARDWARE
- STEP 5** INSURE ALL PARTS ARE PROPERLY ALIGNED AND TIGHTEN ALL BOLTS. TIGHTEN THE TUBE STEP BOLTS FIRST TO 65 FT./LBS. TIGHTEN THE BRACKET BOLTS NEXT TO 35 FT/LBS.
- STEP 6** REPEAT STEPS 2 THROUGH 5 FOR INSTALLATION OF PASSENGER SIDE.

QTY	PARTS LIST	QTY	PARTS LIST
2	1410 Front Bracket	4	1/2" Lock Washer
2	1410 Rear Bracket	12	5/16" - 18 / 1-1/2" Flange bolt
4	1/2" - 13 x 1 - 3/4" Hex Bolt	12	5/16" Nut Clip
4	1/2" Flat Washer		

**For use on 52,53,42,43 series** (extra parts for rear bracket only)

2	1/2" Nut	2	1/2" Lock Washer
2	1/2" Flat Washer		

## MAINTENANCE AND CARE

Only use mild soap for regular cleaning. For heavy build up, a solution of ammonia and water can be used. Never use an abrasive material, i.e. steel wool, for cleaning purposes. Use terry cloth towels wiping in the direction of the tube at all times.

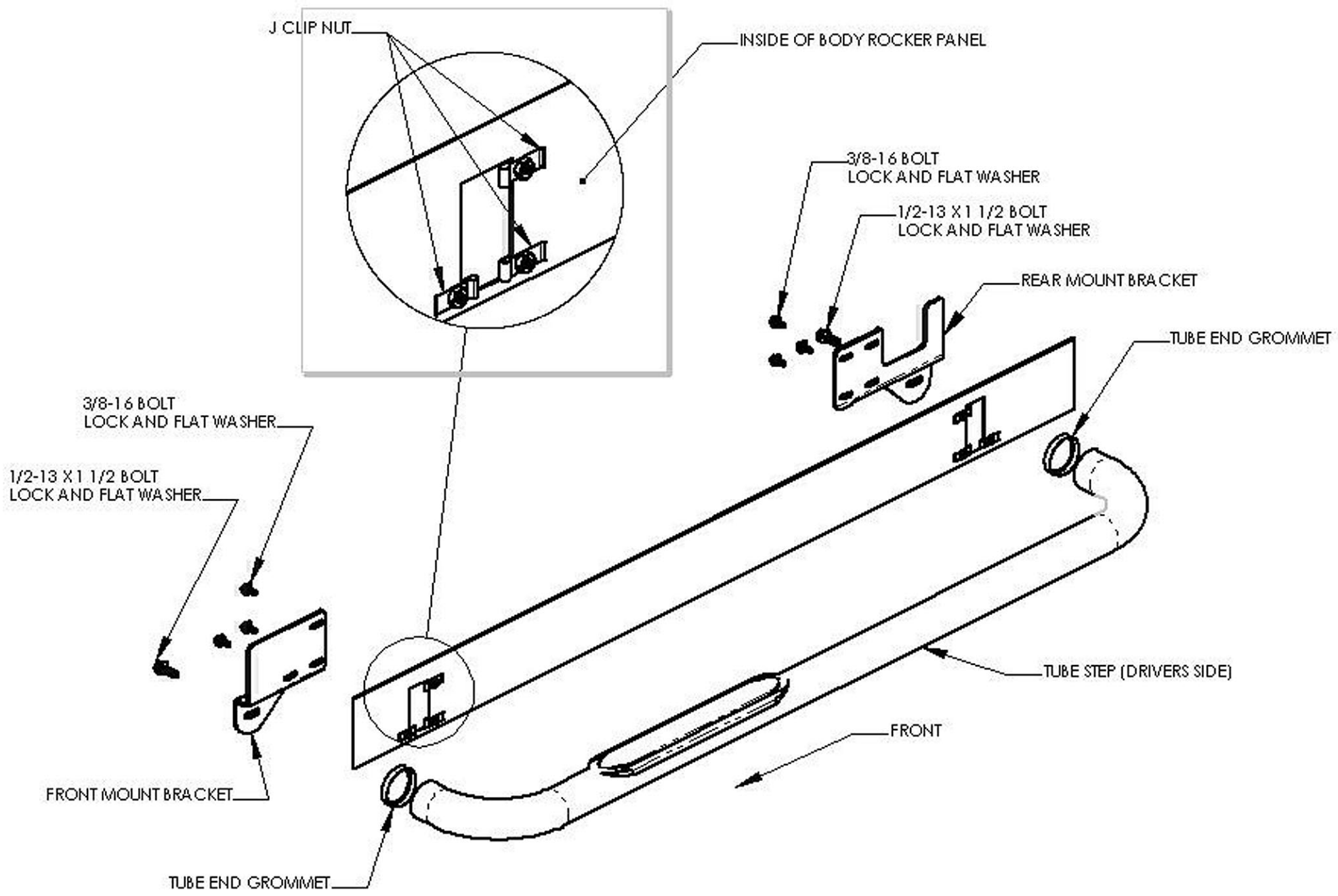

Plastic tube rings available on 3" diameter tube steps only.

**DRIVERS SIDE**