

Drop Step - 3"

(866) 476-6276 / (866) IRONCROSS
www.ironcrossautomotive.com
519 W. Dewey
Sapulpa, OK 74066
IRON CROSS AUTOMOTIVE INC. 2008

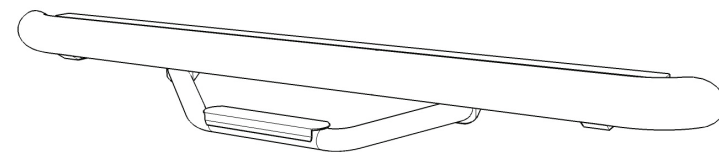

PARTS LIST

QTY	PARTS
2	Drop Step
8	3/8" Flange Bolts
4	4"x1.25" Rail-tab

****Drop step is designed to work with tube and rail system that is purchased separately.**

DROP STEP INSTALLATION

- 1) Remove contents from box and check for damaged parts. Verify all parts are present, making sure to read and understand instructions before install.
- 2) Tube and rail should be mounted to vehicle before drop step installation.
- 3) Place (2) 4" wide threaded rail-tabs up into rail. Turn tab with fingers until tab can slide into narrow opening on the bottom of the rail.
- 4) Position step brace to rail and rail-tabs. Thread 3/8" flange bolt through holes on outer ends of step brace. Leave loose and hand tighten at this time.
- 5) Thread 3/8" flange bolt into the inner holes of step brace. Leave loose and hand tighten at this time.
- 6) With all (4) bolts lightly threaded into rail-tabs, slide step to desired position on rail.
- 7) Once in position, tighten outer (2) bolts first and then inner (2) bolts.
- 8) Repeat process to install step to other side of vehicle

Patented pending design allows an adjustable foot step to be positioned at any mounting point along tube.

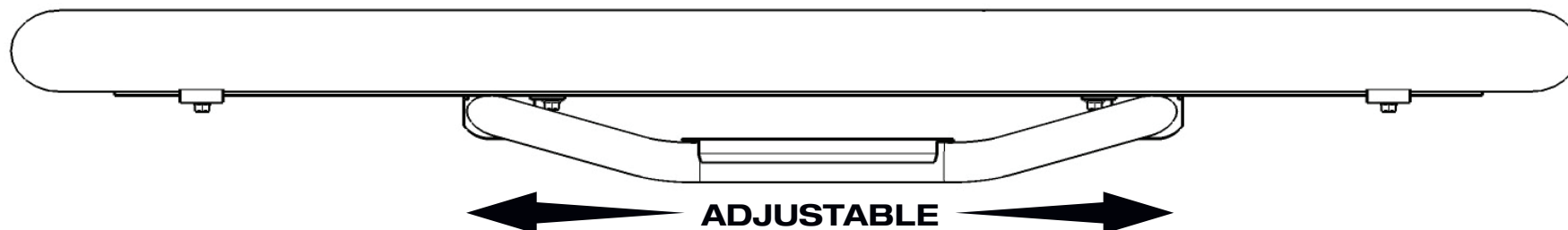

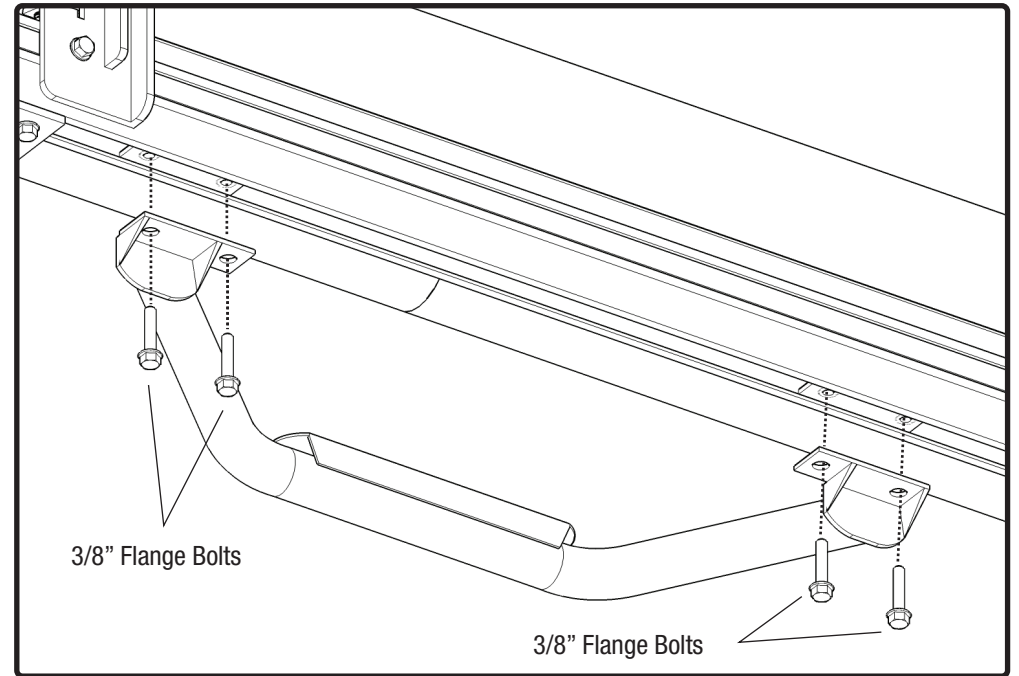
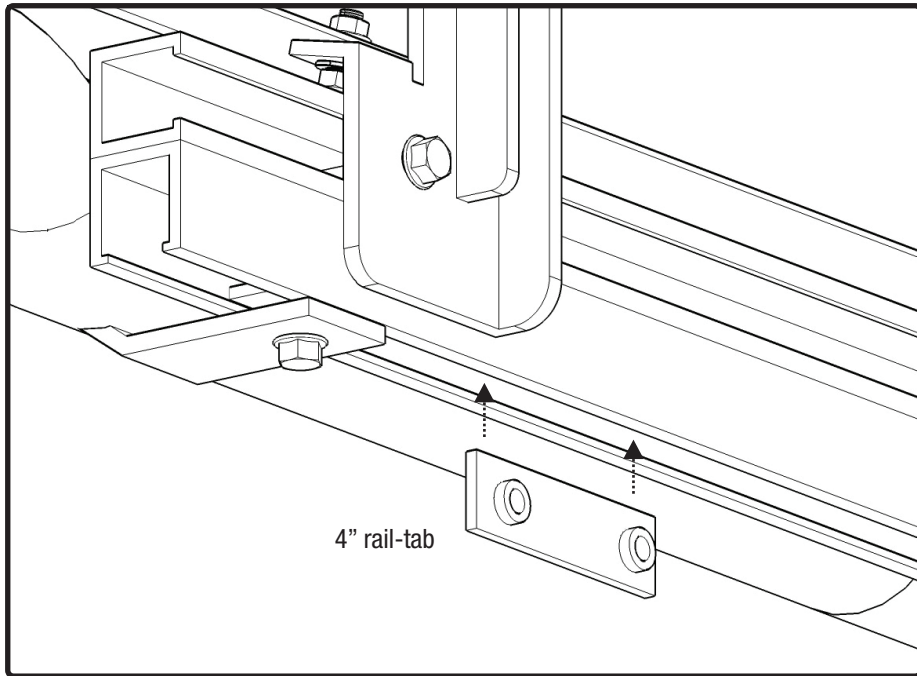

Step is designed to slide to the right and left along rail. Once in desired position, tighten all bolts.

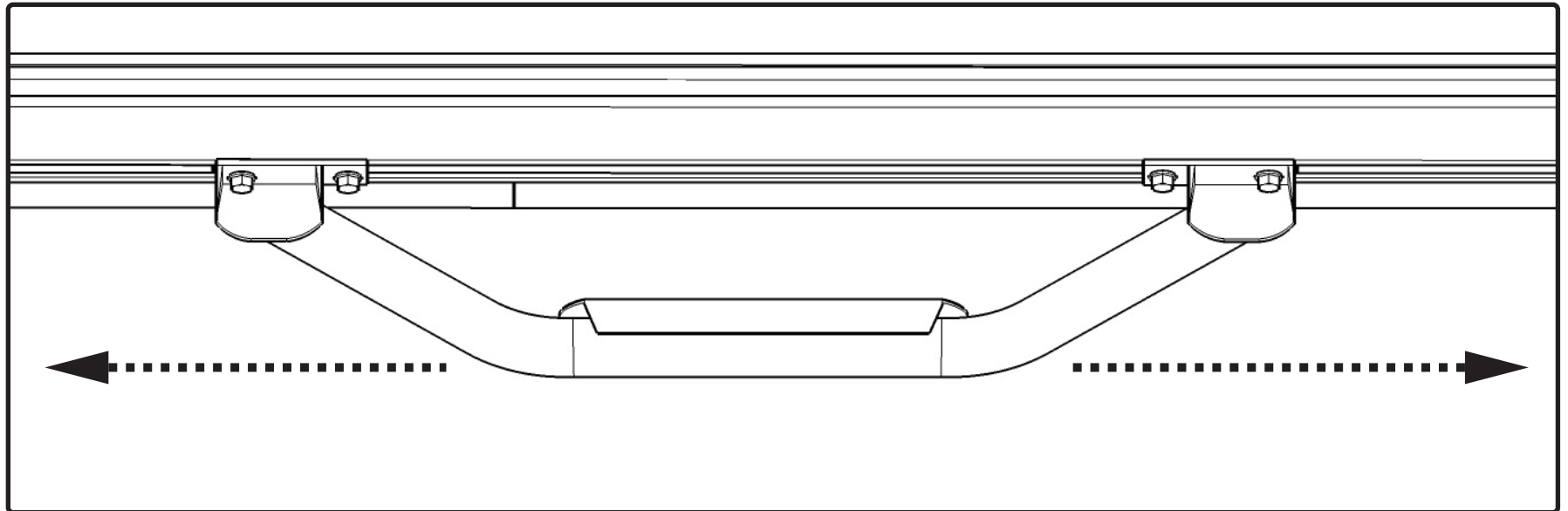

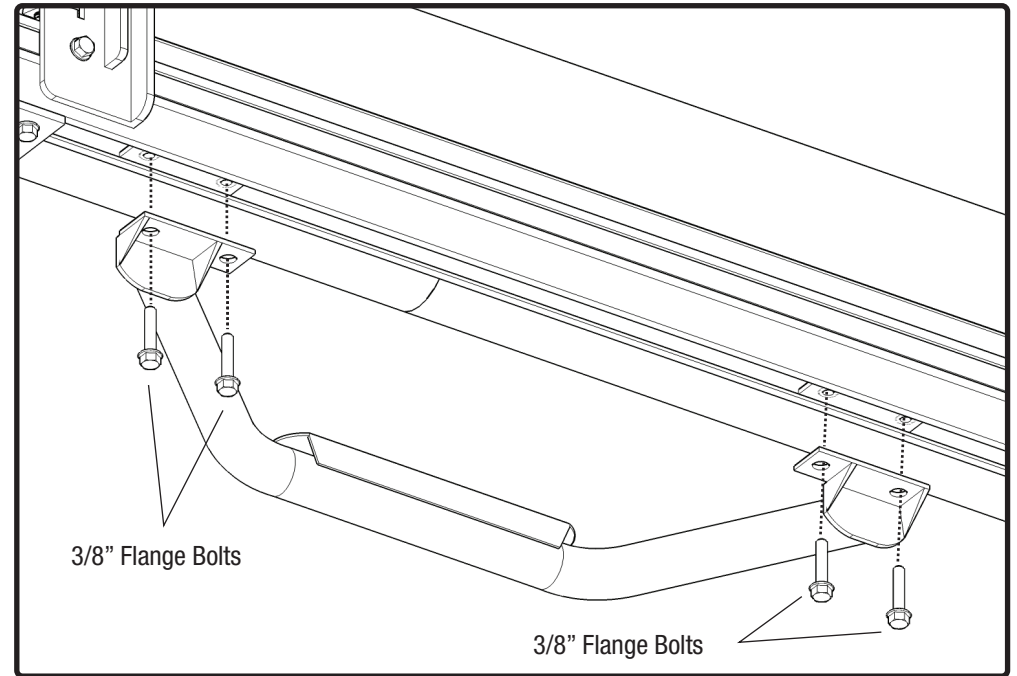
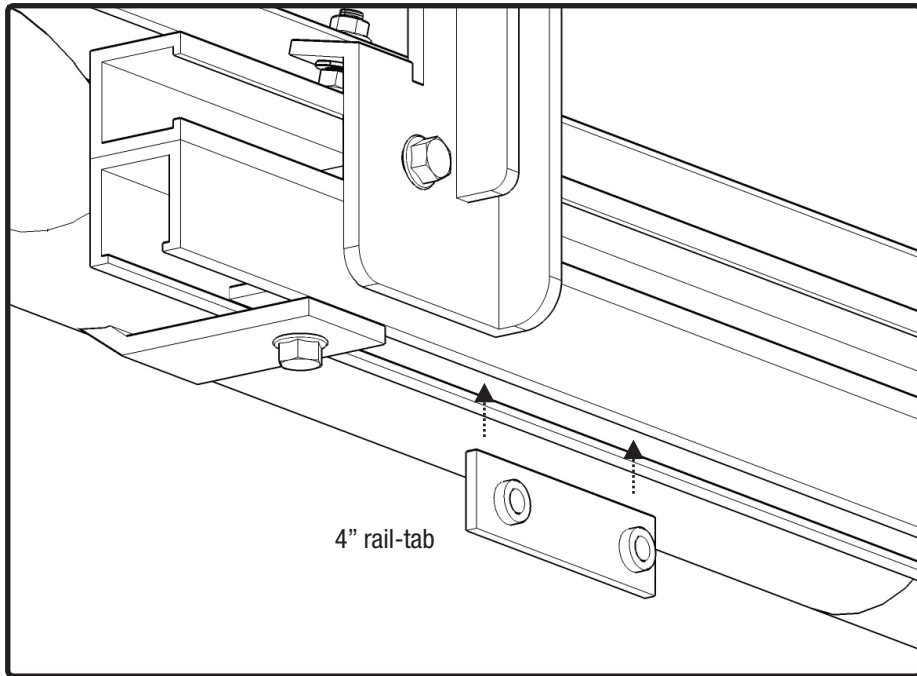

Step is designed to slide to the right and left along rail. Once in desired position, tighten all bolts.

